

SERA 1

RASHID YACHTS & MARINA

FLOOR PLAN
TOWNHOUSE

EMAAR

RASHID YACHTS & MARINA



SWIMMING
POOL

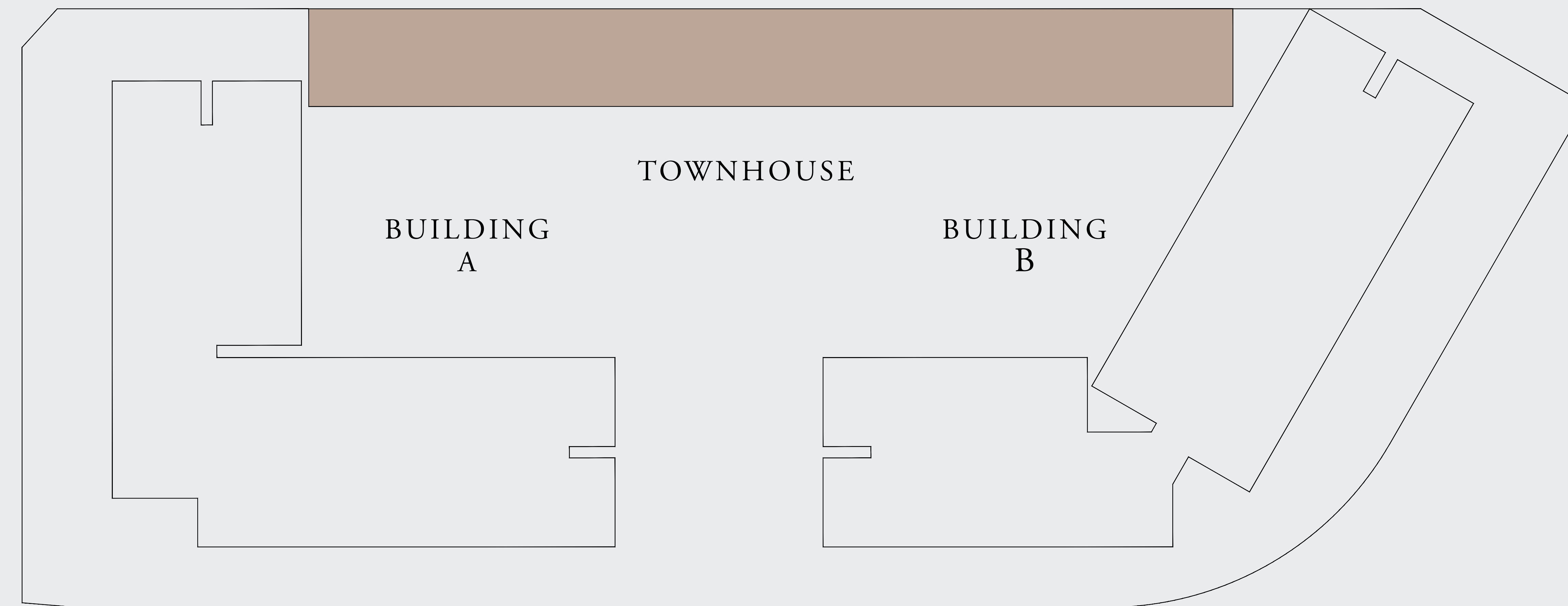

EMAAR

SERA I

RASHID YACHTS & MARINA

TOWNHOUSE TOWNHOUSE TYPE A1

UNITS 03, 07

SUITE AREA	205.26 SQ.M.	2209.40 SQ.FT.
BALCONY AREA	33.26 SQ.M.	358.01 SQ.FT.
TOTAL AREA	238.52 SQ.M.	2567.41 SQ.FT.

KEY SECTION

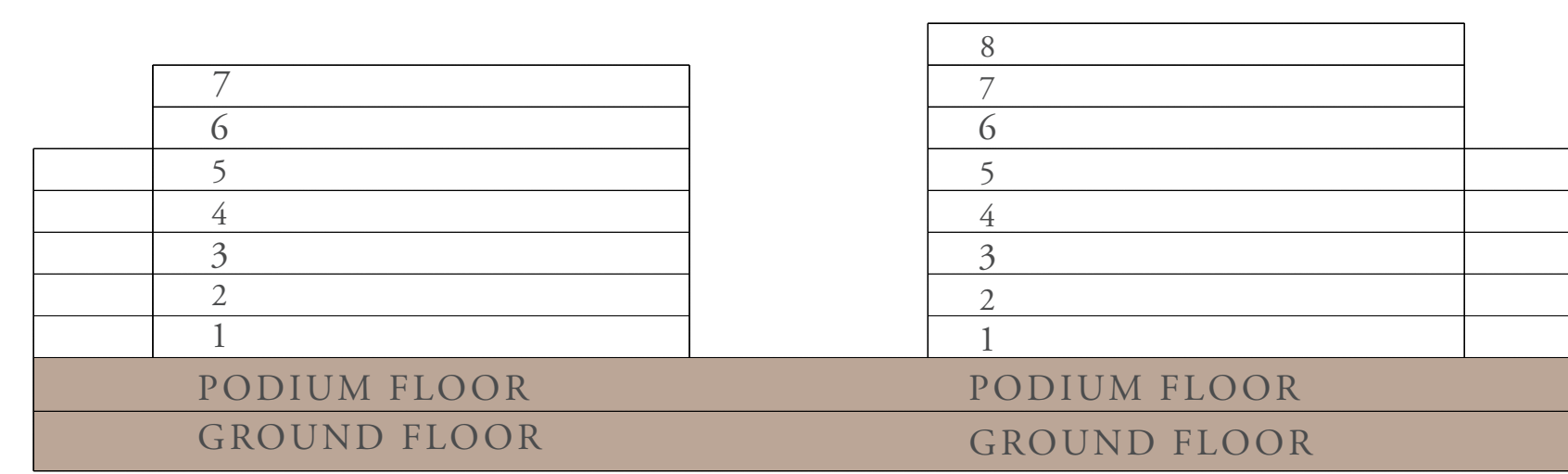

LAYOUT

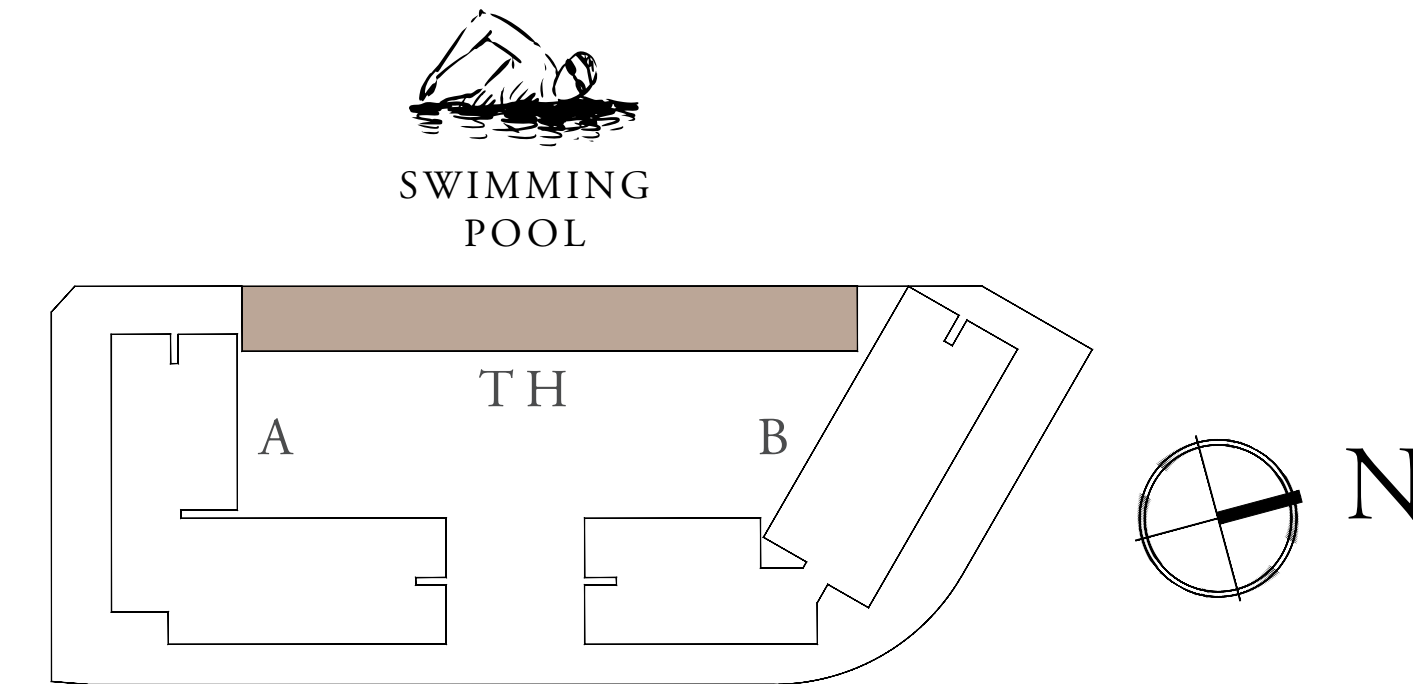

KEY PLAN

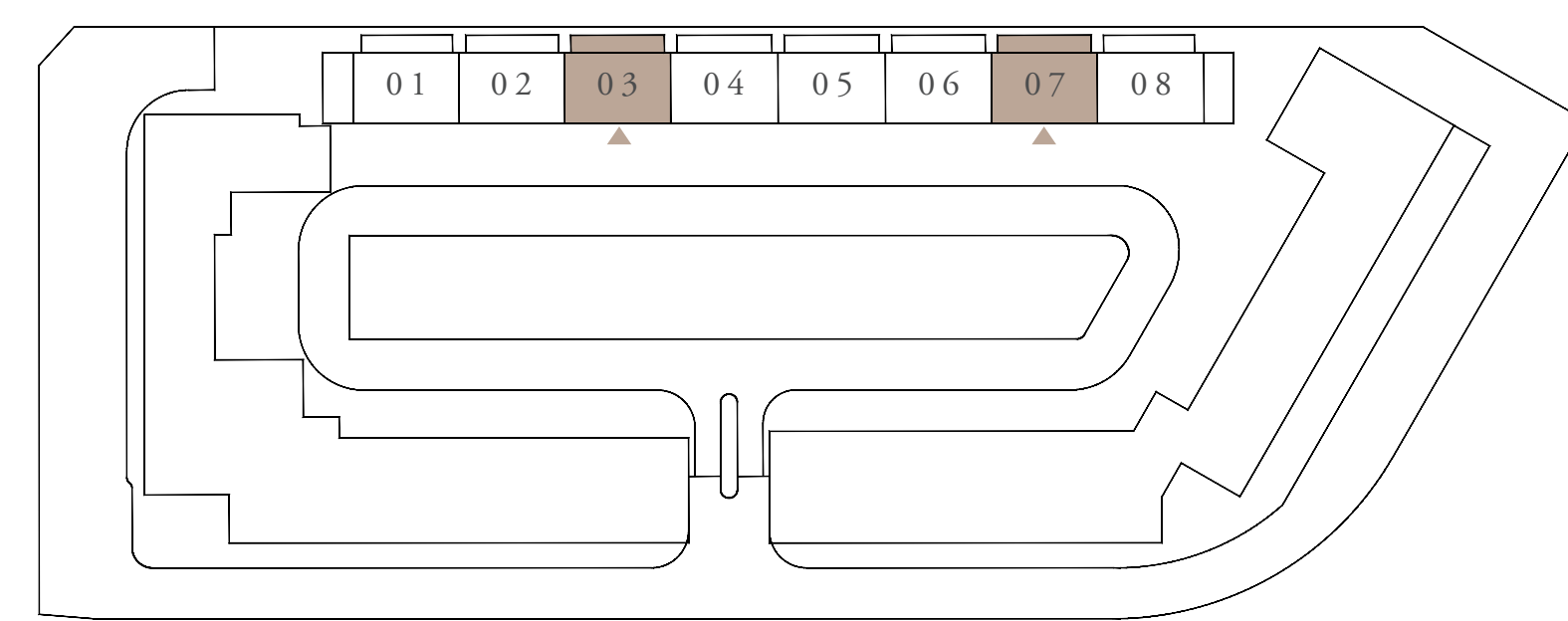

GROUND FLOOR LEVEL

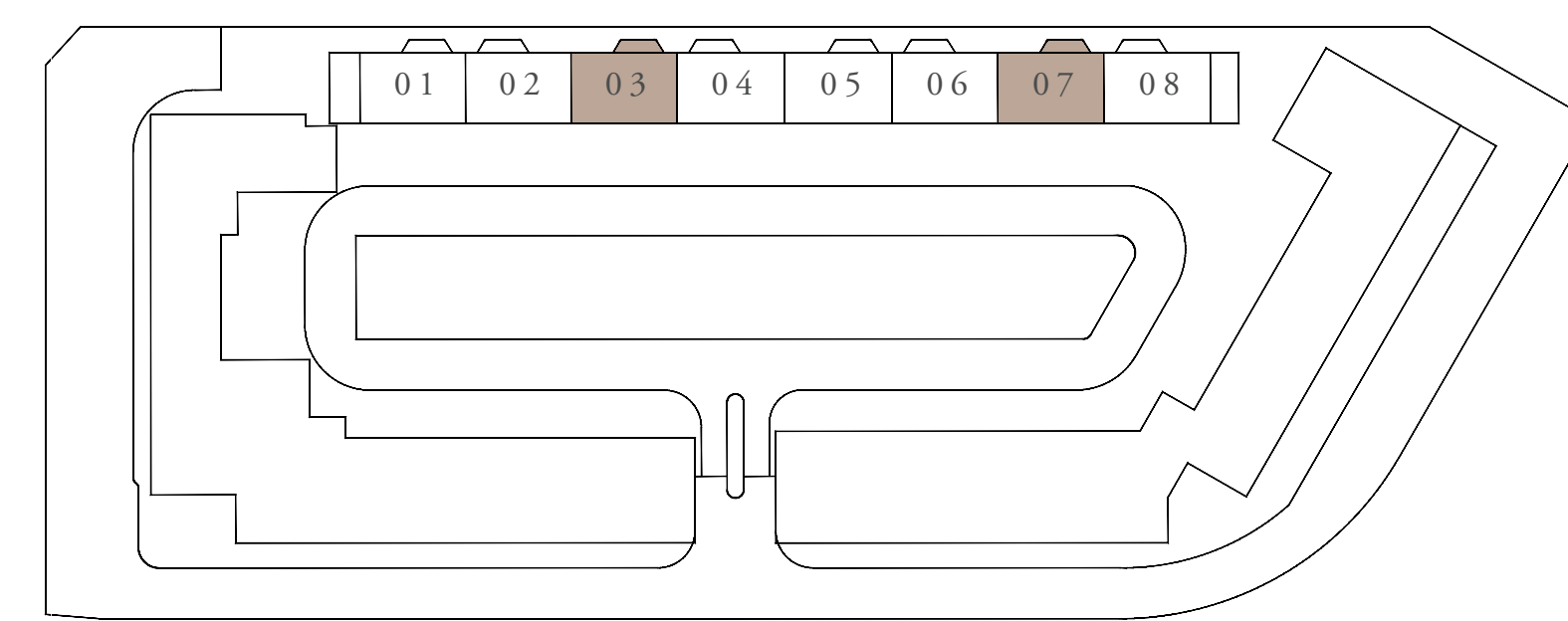

PODIUM FLOOR LEVEL



UPPER LEVEL



LOWER LEVEL

FLOOR PLAN 1. All dimensions are in imperial and metric, and measured from finish to finish excluding construction tolerances. 2. All materials, dimensions, and drawings are approximate only. 3. Information is subject to change without notice, at developer's absolute discretion. 4. Actual area may vary from the stated area. 5. Drawings not to scale. 6. All images used are for illustrative purposes only and do not represent the actual size, features, specifications, fittings, and furnishings. 7. The developer reserves the right to make revisions / alterations, at it's absolute discretion, without any liability whatsoever.

SERA I

RASHID YACHTS & MARINA

TOWNHOUSE TOWNHOUSE TYPE A1

UNITS 01

SUITE AREA	206.14 SQ.M.	2218.87 SQ.FT.
BALCONY AREA	32.87 SQ.M.	353.81 SQ.FT.
TOTAL AREA	239.01 SQ.M.	2572.68 SQ.FT.

KEY SECTION

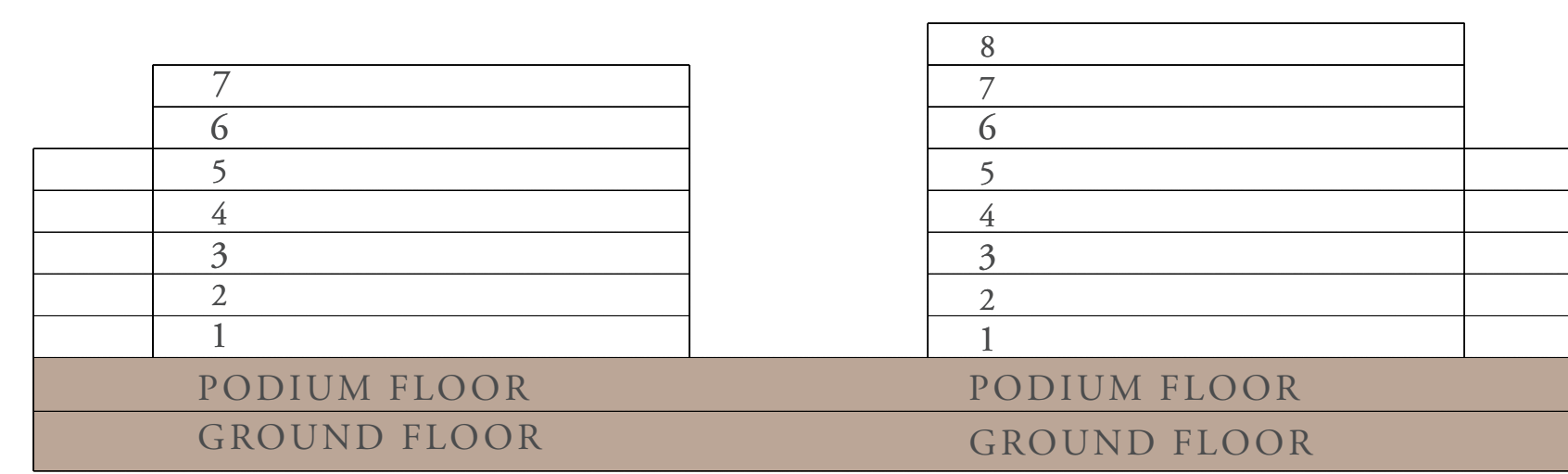

LAYOUT

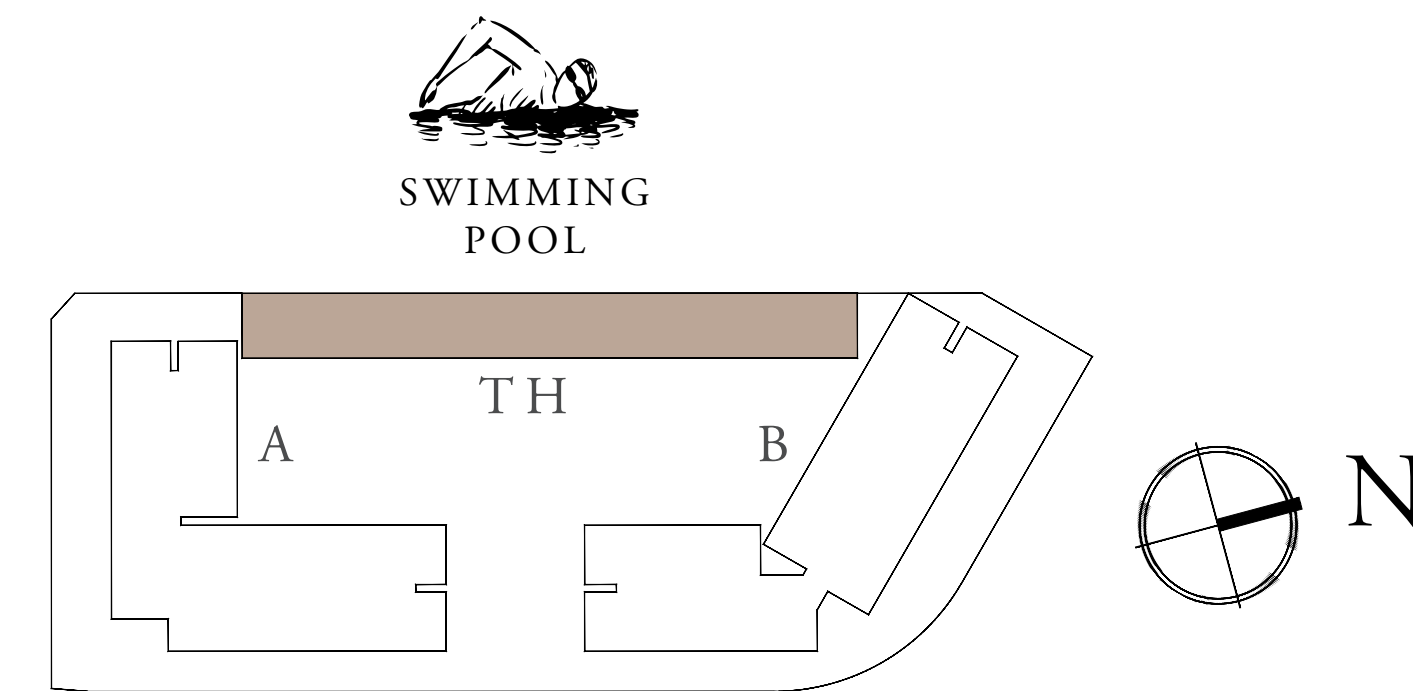

KEY PLAN

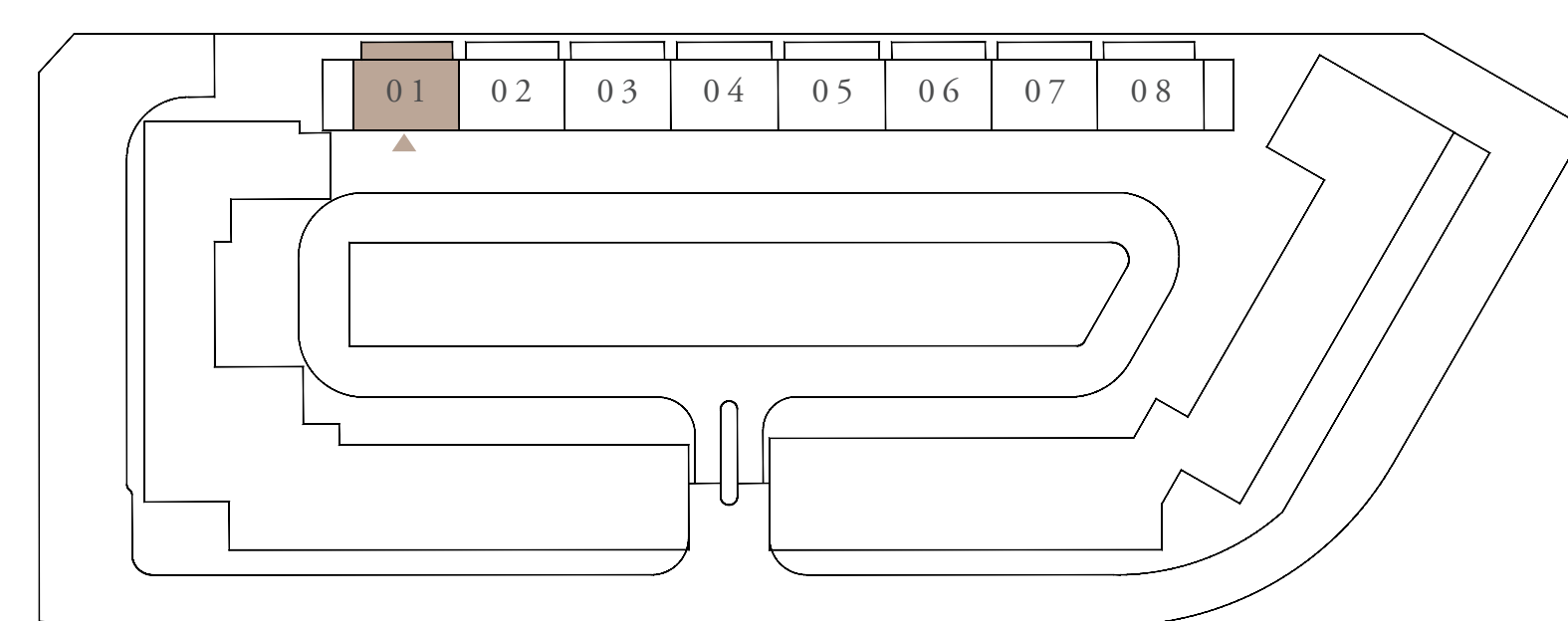

GROUND FLOOR LEVEL

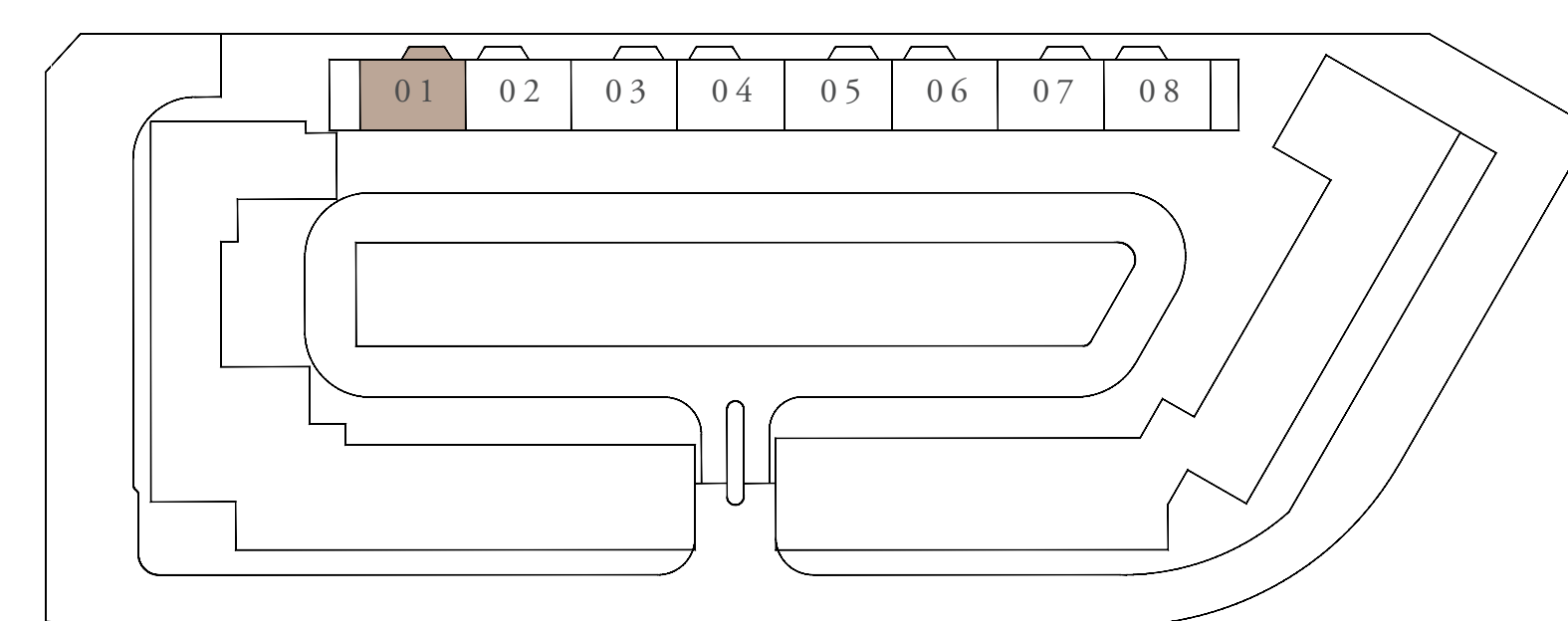

PODIUM FLOOR LEVEL



UPPER LEVEL



LOWER LEVEL

FLOOR PLAN 1. All dimensions are in imperial and metric, and measured from finish to finish excluding construction tolerances. 2. All materials, dimensions, and drawings are approximate only. 3. Information is subject to change without notice, at developer's absolute discretion. 4. Actual area may vary from the stated area. 5. Drawings not to scale. 6. All images used are for illustrative purposes only and do not represent the actual size, features, specifications, fittings, and furnishings. 7. The developer reserves the right to make revisions / alterations, at it's absolute discretion, without any liability whatsoever.

SERA I

RASHID YACHTS & MARINA

TOWNHOUSE TOWNHOUSE TYPE A1

UNITS 05

SUITE AREA	206.90 SQ.M.	2227.05 SQ.FT.
BALCONY AREA	33.72 SQ.M.	362.96 SQ.FT.
TOTAL AREA	240.62 SQ.M.	2590.01 SQ.FT.

KEY SECTION

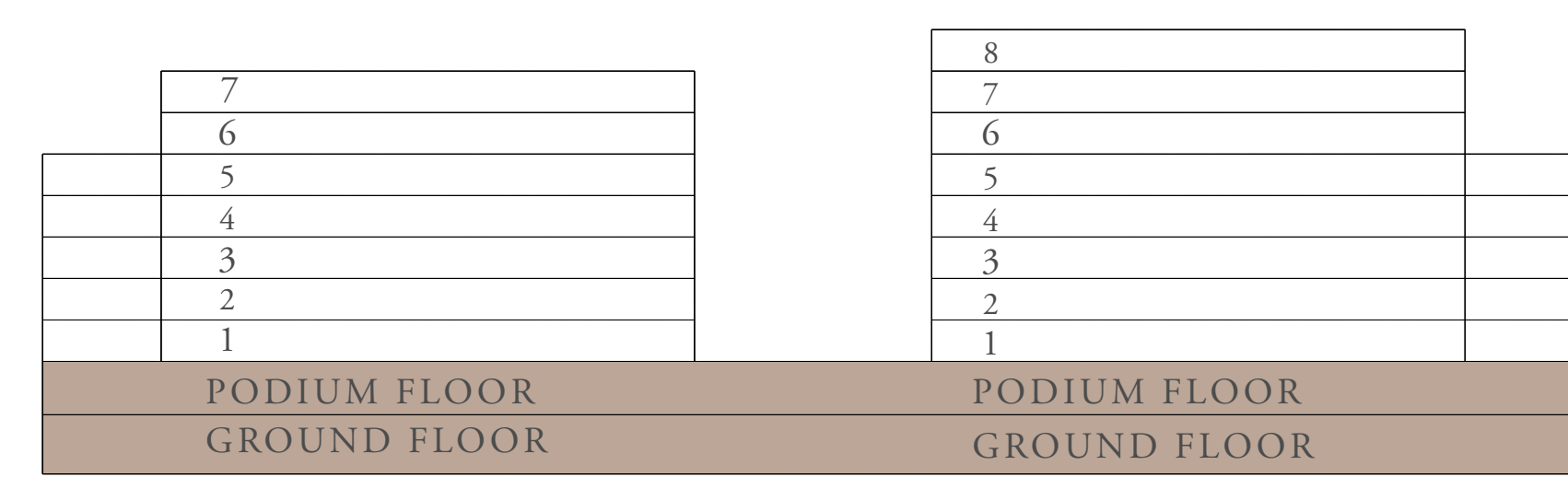

LAYOUT

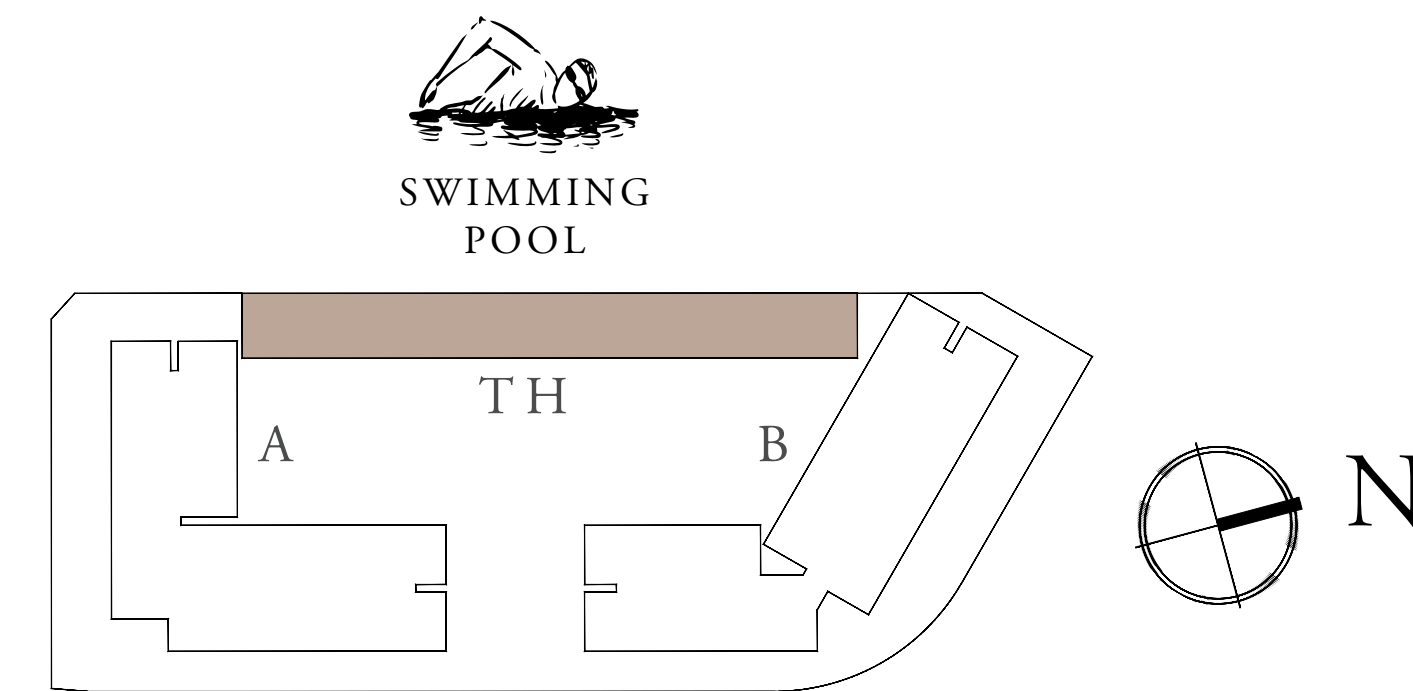

KEY PLAN

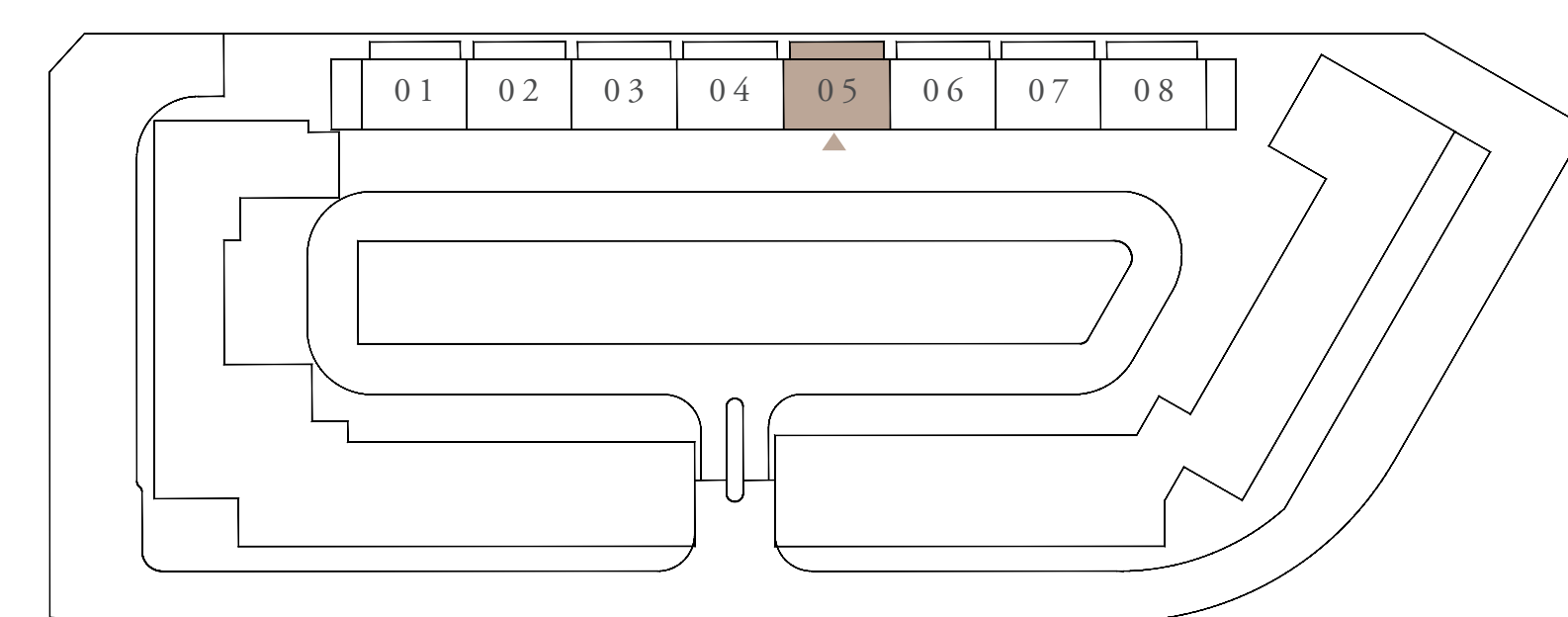

GROUND FLOOR LEVEL

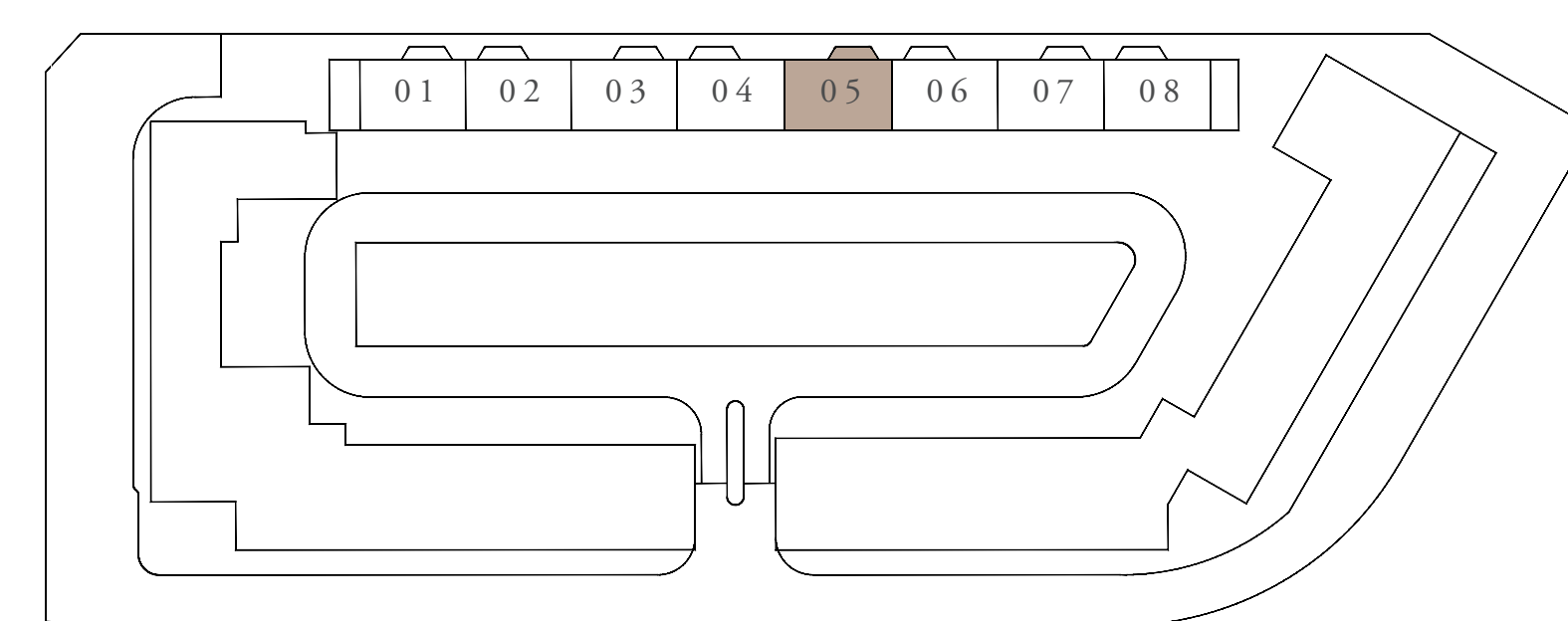

PODIUM FLOOR LEVEL



UPPER LEVEL



LOWER LEVEL

FLOOR PLAN 1. All dimensions are in imperial and metric, and measured from finish to finish excluding construction tolerances. 2. All materials, dimensions, and drawings are approximate only. 3. Information is subject to change without notice, at developer's absolute discretion. 4. Actual area may vary from the stated area. 5. Drawings not to scale. 6. All images used are for illustrative purposes only and do not represent the actual size, features, specifications, fittings, and furnishings. 7. The developer reserves the right to make revisions / alterations, at it's absolute discretion, without any liability whatsoever.

SERA 1

RASHID YACHTS & MARINA

TOWNHOUSE TOWNHOUSE TYPE A2

UNITS 02, 06

SUITE AREA	205.26 SQ.M.	2209.40 SQ.FT.
BALCONY AREA	33.26 SQ.M.	358.01 SQ.FT.
TOTAL AREA	238.52 SQ.M.	2567.41 SQ.FT.

KEY SECTION

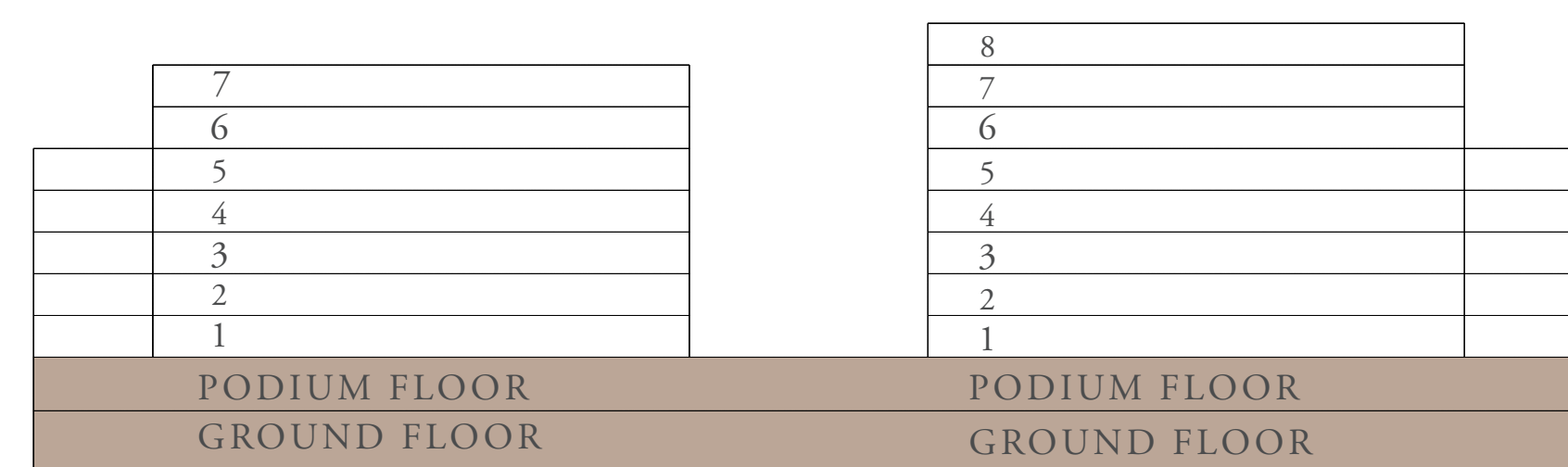

LAYOUT

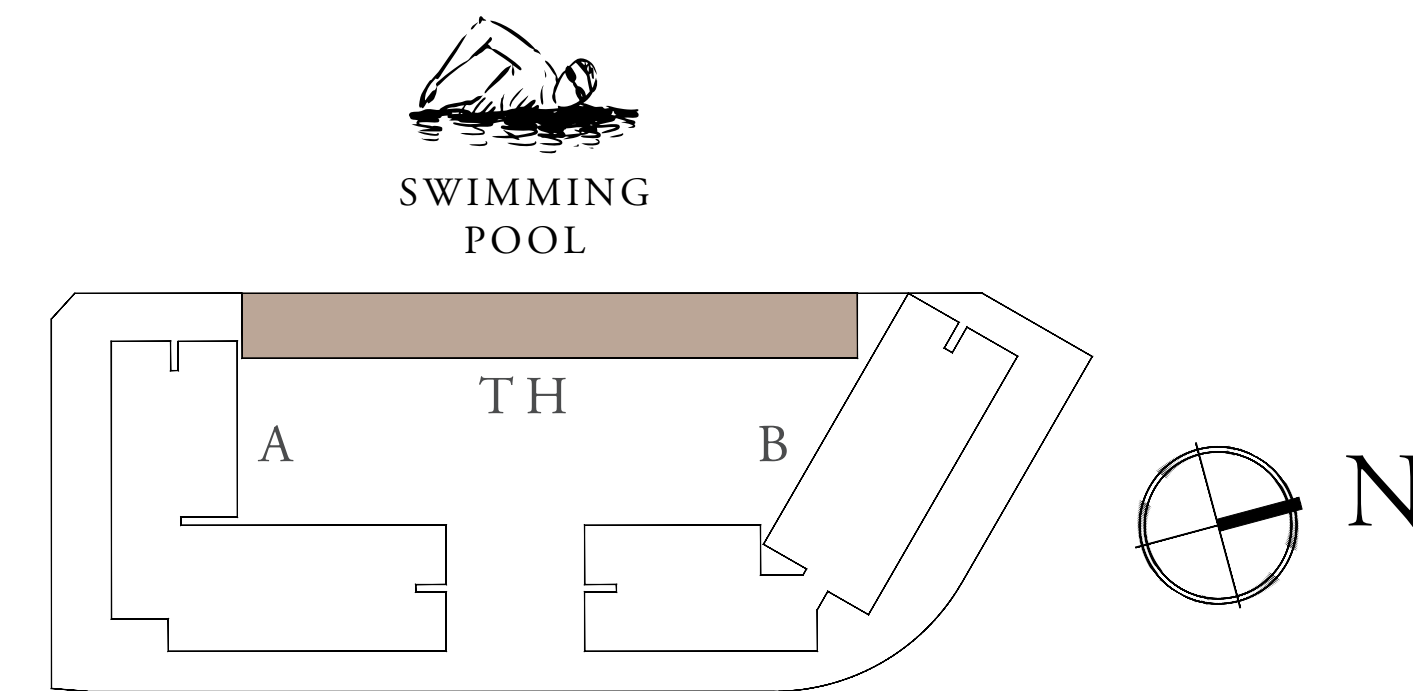

KEY PLAN

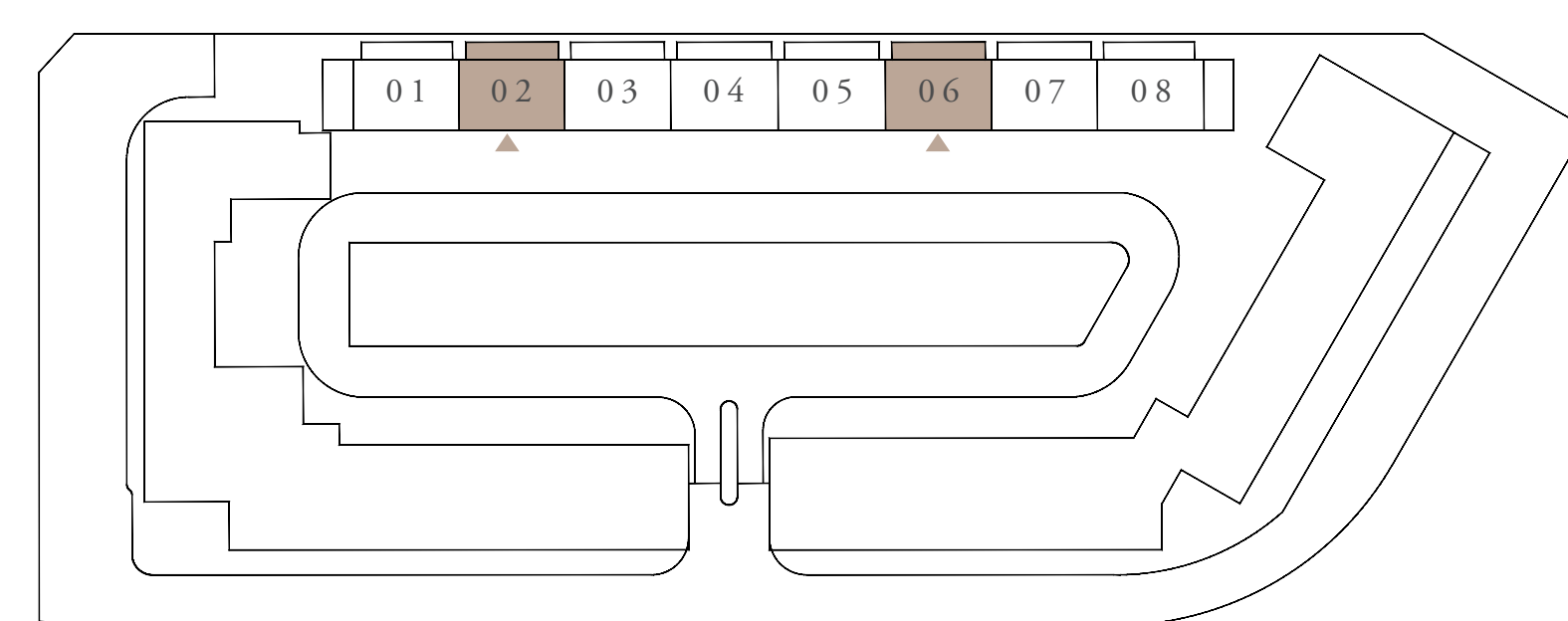

GROUND FLOOR LEVEL

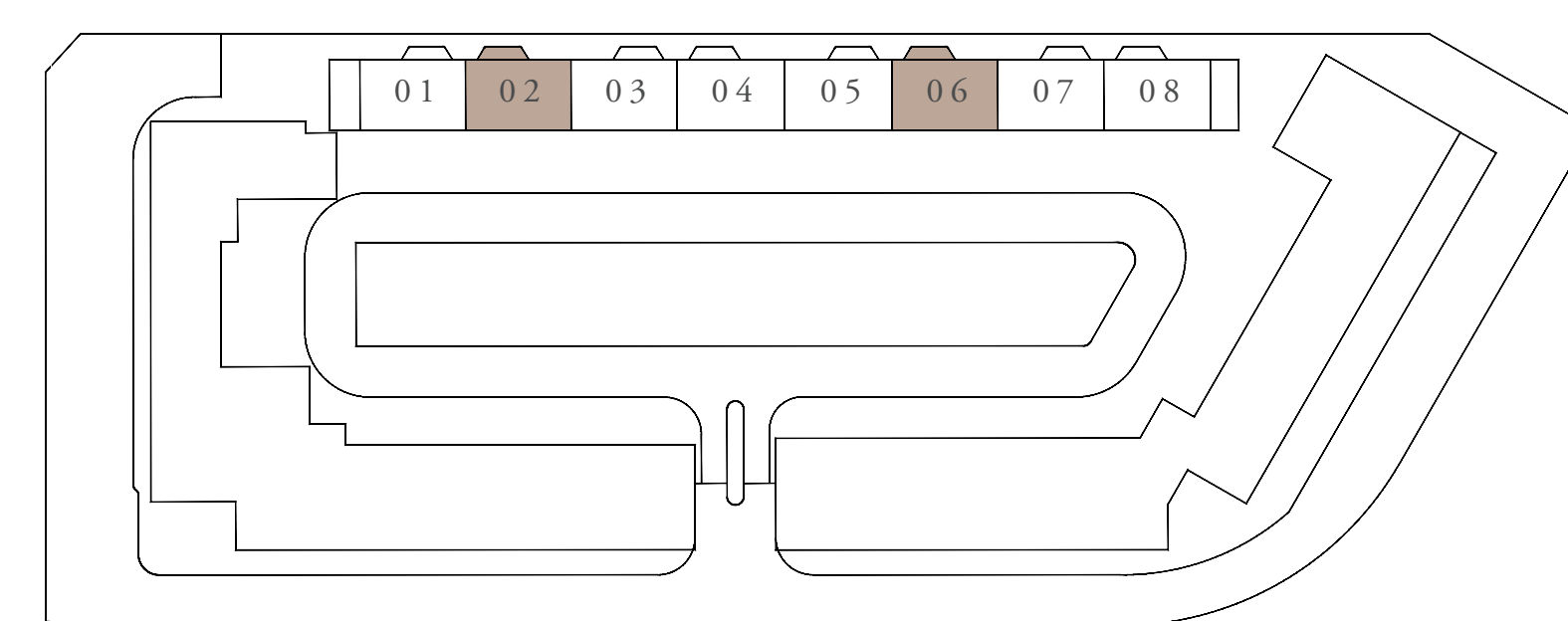

PODIUM FLOOR LEVEL



UPPER LEVEL



LOWER LEVEL

FLOOR PLAN 1. All dimensions are in imperial and metric, and measured from finish to finish excluding construction tolerances. 2. All materials, dimensions, and drawings are approximate only. 3. Information is subject to change without notice, at developer's absolute discretion. 4. Actual area may vary from the stated area. 5. Drawings not to scale. 6. All images used are for illustrative purposes only and do not represent the actual size, features, specifications, fittings, and furnishings. 7. The developer reserves the right to make revisions / alterations, at it's absolute discretion, without any liability whatsoever.

SERA 1

RASHID YACHTS & MARINA

TOWNHOUSE TOWNHOUSE TYPE A2

UNITS 08

SUITE AREA	206.26 SQ.M.	2220.16 SQ.FT.
BALCONY AREA	32.60 SQ.M.	350.90 SQ.FT.
TOTAL AREA	238.86 SQ.M.	2571.07 SQ.FT.

KEY SECTION

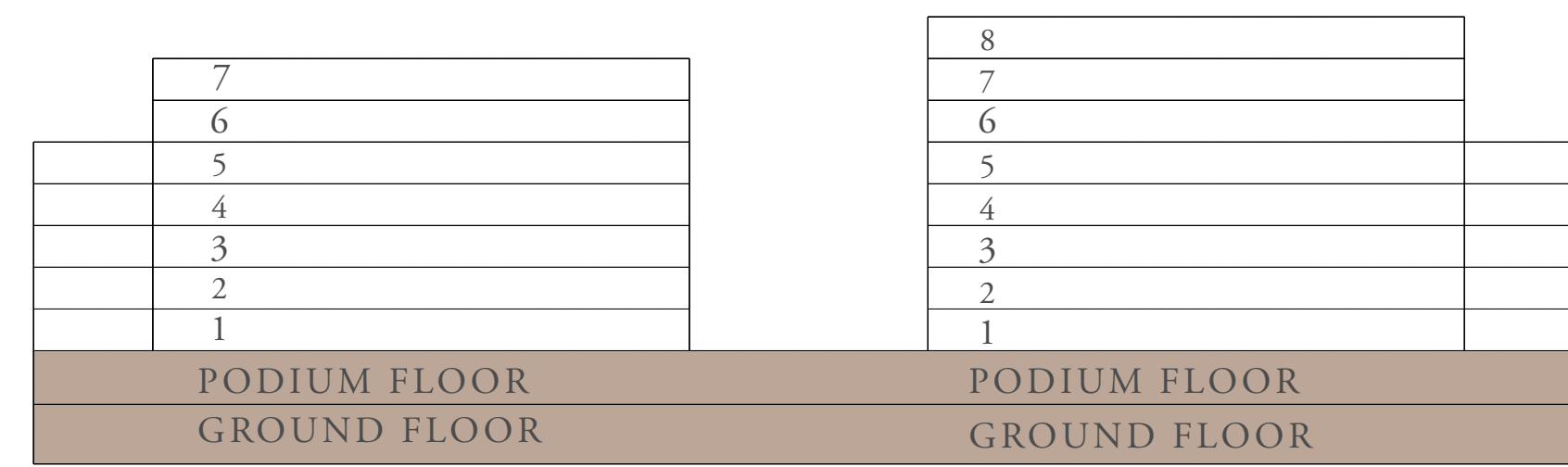

LAYOUT

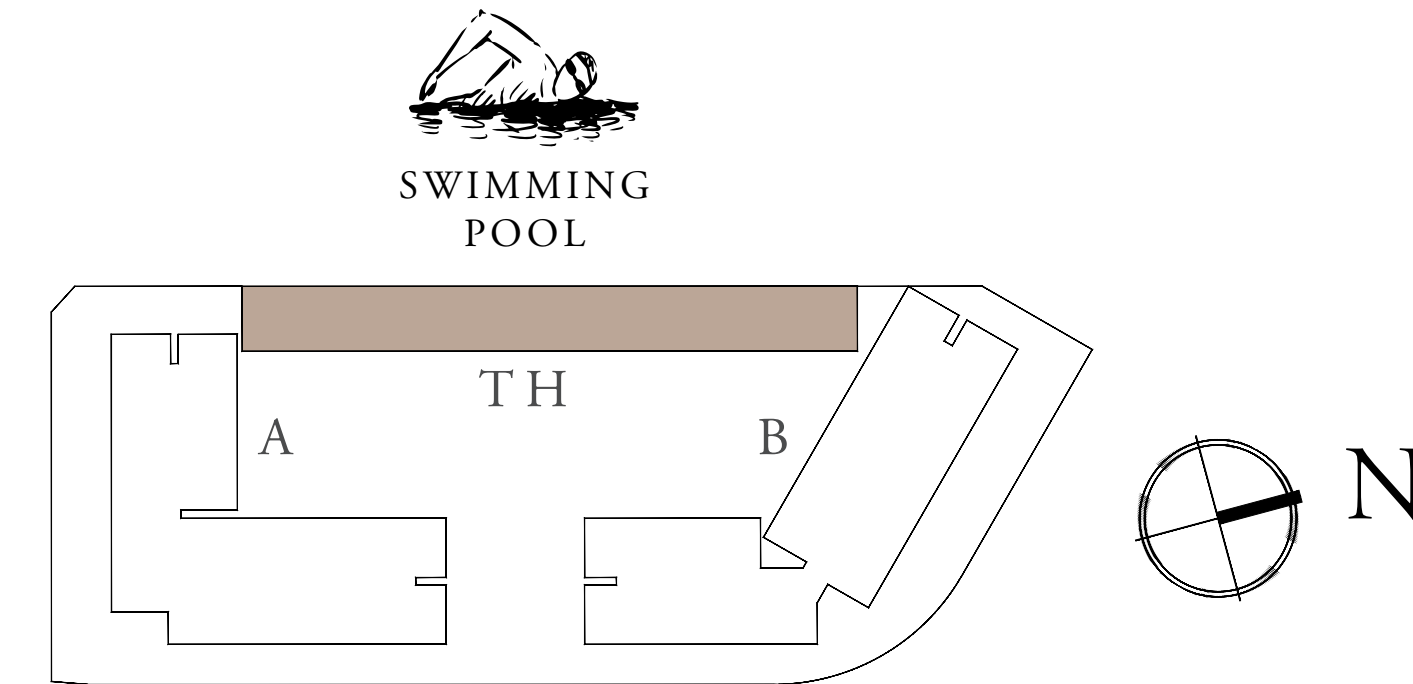

KEY PLAN

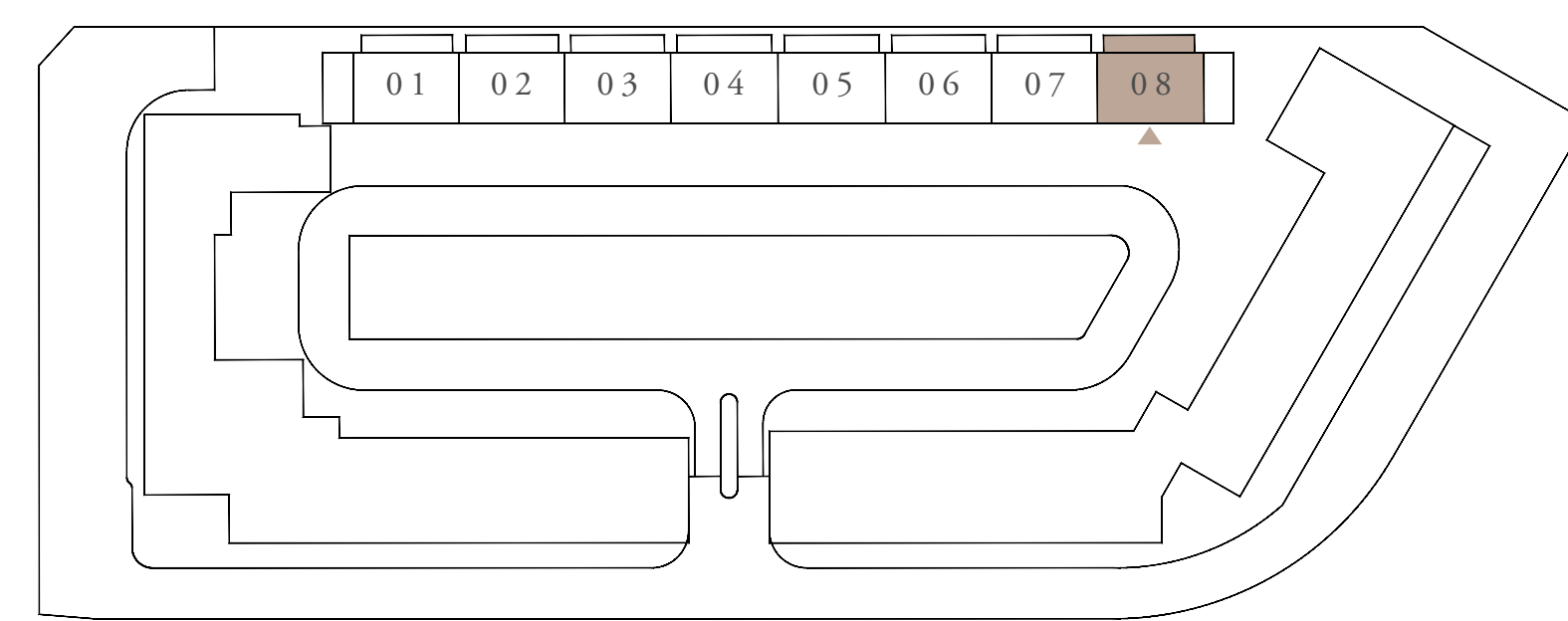

GROUND FLOOR LEVEL

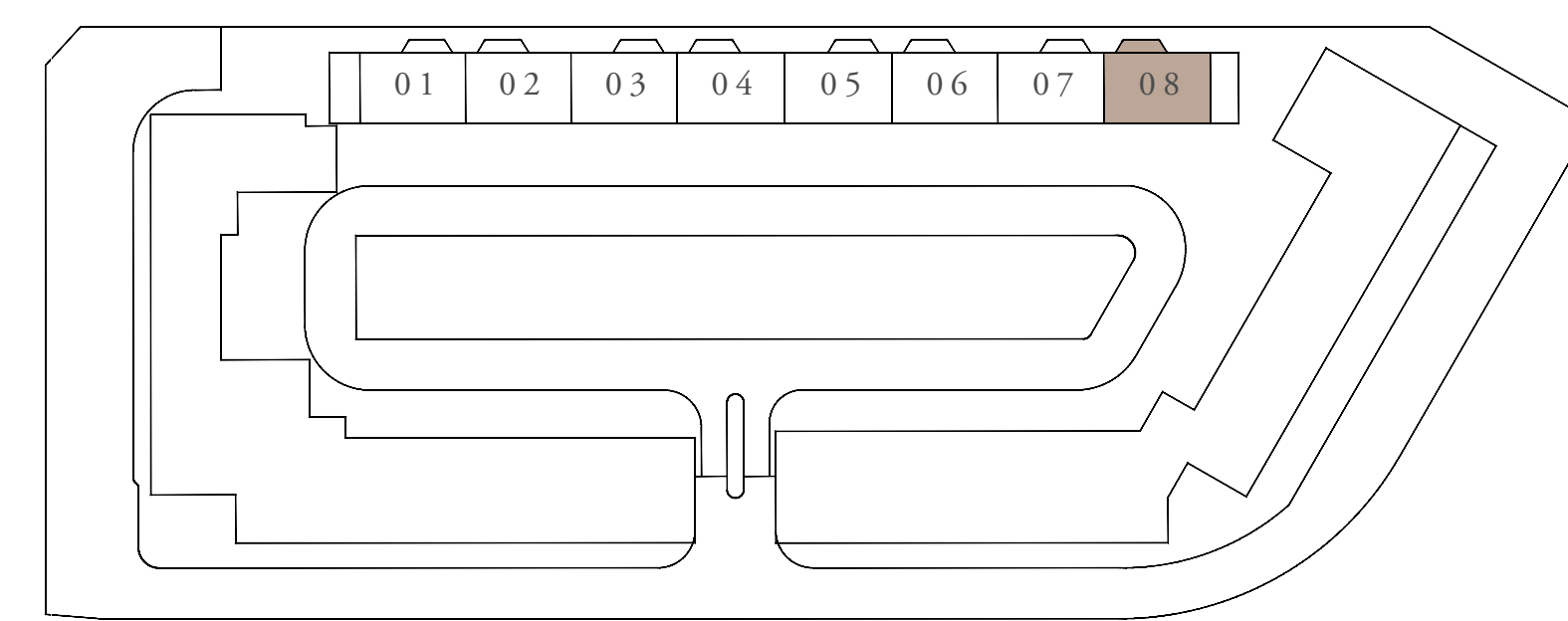

PODIUM FLOOR LEVEL



UPPER LEVEL



LOWER LEVEL

FLOOR PLAN 1. All dimensions are in imperial and metric, and measured from finish to finish excluding construction tolerances. 2. All materials, dimensions, and drawings are approximate only. 3. Information is subject to change without notice, at developer's absolute discretion. 4. Actual area may vary from the stated area. 5. Drawings not to scale. 6. All images used are for illustrative purposes only and do not represent the actual size, features, specifications, fittings, and furnishings. 7. The developer reserves the right to make revisions / alterations, at it's absolute discretion, without any liability whatsoever.

SERA 1

RASHID YACHTS & MARINA

TOWNHOUSE TOWNHOUSE TYPE A2

UNITS 04

SUITE AREA	207.02 SQ.M.	2228.34 SQ.FT.
BALCONY AREA	33.72 SQ.M.	362.96 SQ.FT.
TOTAL AREA	240.74 SQ.M.	2591.30 SQ.FT.

KEY SECTION

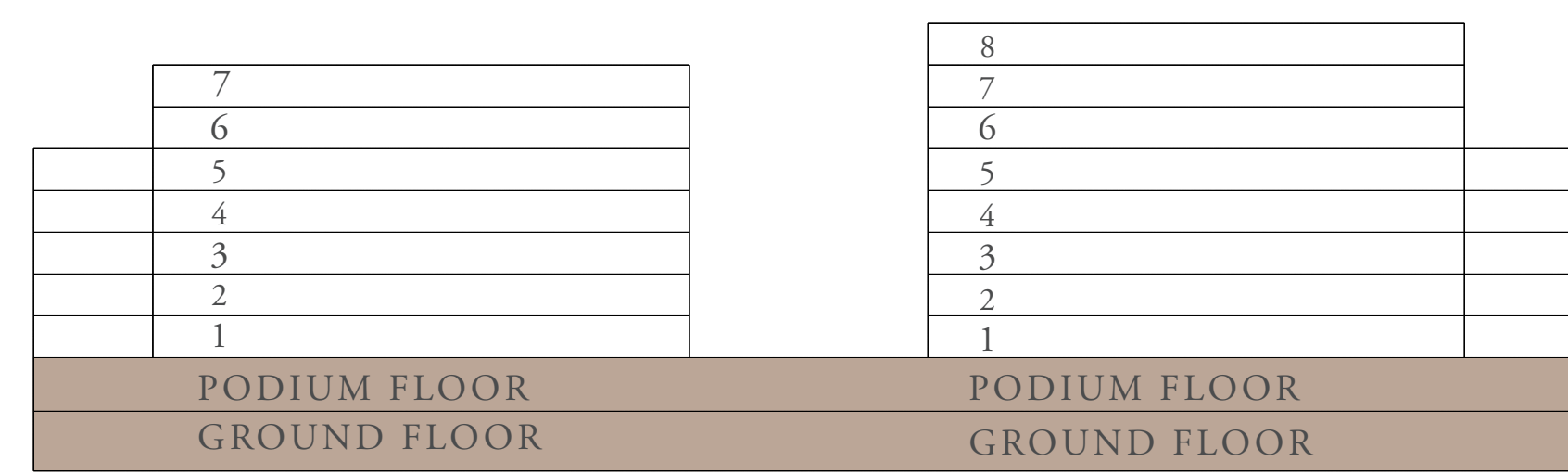

LAYOUT

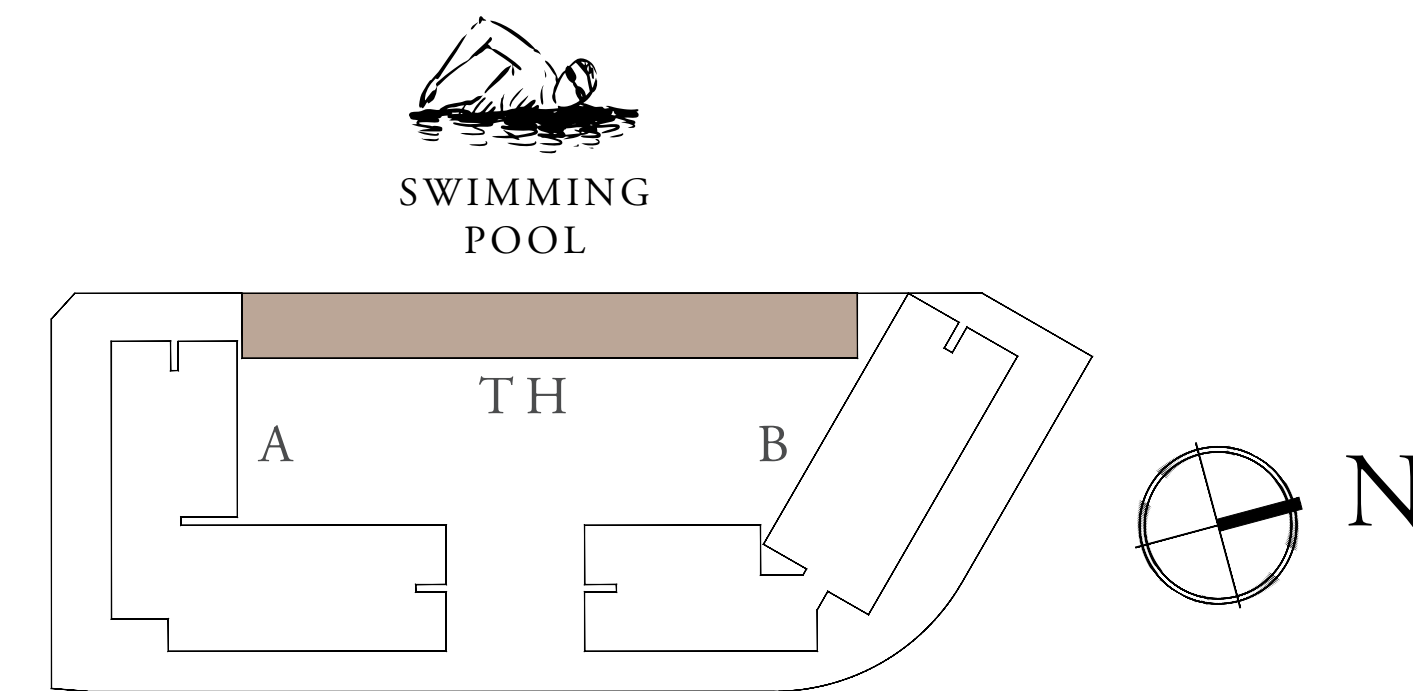

KEY PLAN

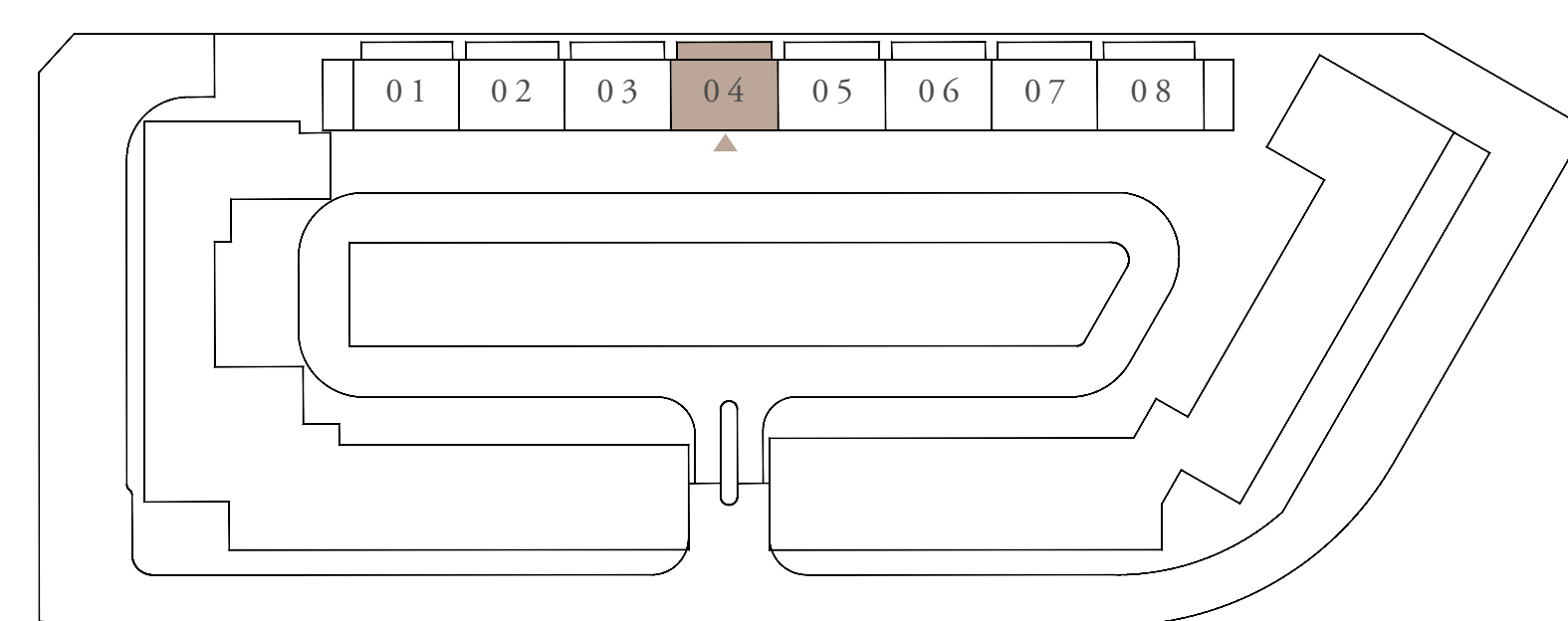

GROUND FLOOR LEVEL

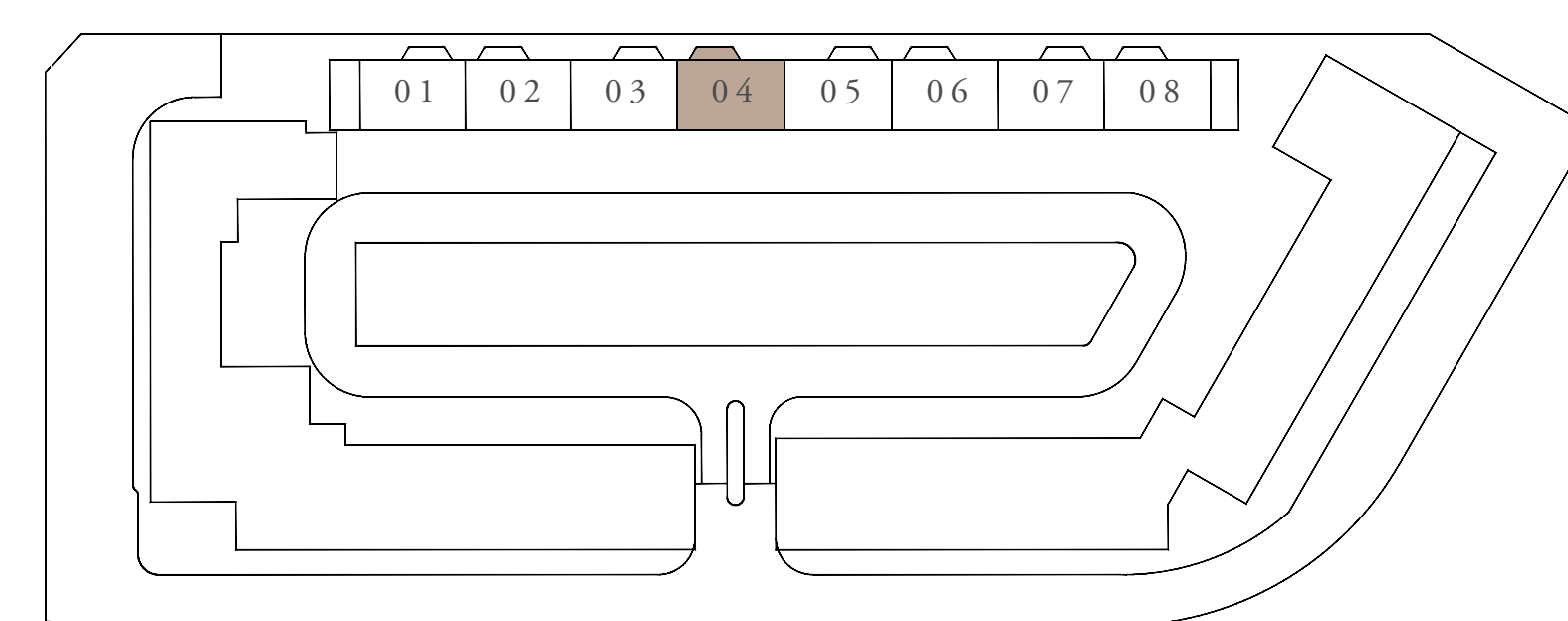

PODIUM FLOOR LEVEL



UPPER LEVEL



LOWER LEVEL

FLOOR PLAN 1. All dimensions are in imperial and metric, and measured from finish to finish excluding construction tolerances. 2. All materials, dimensions, and drawings are approximate only. 3. Information is subject to change without notice, at developer's absolute discretion. 4. Actual area may vary from the stated area. 5. Drawings not to scale. 6. All images used are for illustrative purposes only and do not represent the actual size, features, specifications, fittings, and furnishings. 7. The developer reserves the right to make revisions / alterations, at it's absolute discretion, without any liability whatsoever.