

EW

EDGEWATER
RESIDENCES

PHASE 3

Premium Seaview Living



An aerial photograph of a beach with turquoise water and white foam. The water is a deep, vibrant blue, and the foam is a bright, creamy white. The beach is a light tan color, and the overall scene is serene and beautiful.

UNLOCK TRANQUIL
seaside lifestyle

Step into a world of elegance and serenity at **Edgewater Residences**, where modern sophistication meets waterfront bliss. With breathtaking views of the sea, this exclusive community offers an unparalleled lifestyle in the heart of **Dubai Islands**.



UNMATCHED
LIVING EXPERIENCE
*in the heart
of Dubai Islands*

Prime location

with direct access to the sea

Vibrant lifestyle hub

featuring shopping, dining, and entertainment

Exclusive amenities

including clubhouse, wellness zones, lush
landscapes, and even more



MGS DEVELOPMENT

Edgewater Residences is created by **MGS Development**, a renowned real estate company dedicated to delivering world-class residential projects. With a commitment to excellence, innovation, and sustainability, the developer has earned a reputation for creating luxurious, future-forward living spaces that redefine modern elegance.

AYENK

As a key partner in this landmark project, renowned American architects **AYENK** based in Miami, Florida, have brought their expertise in luxury waterfront design, ensuring a perfect balance of sophistication and serenity.



DUBAI ISLANDS — THE NEXT *icon of Dubai*

Dubai Islands — a luxurious 17-square-kilometer waterfront development by Nakheel Properties, the creator of Palm Jumeirah. This exclusive destination features **five unique islands** designed for a refined lifestyle, from a vibrant cultural hub and marina to premium beachfront living, championship golf courses, and ultra-luxury villas.

9

exclusive
marinas

40 km

of new
coastline

21 km

of sandy
beaches

Over 80

world-class hotels
and resorts

30,000+

residential
properties



Location

10 mins

Dubai International Airport

20 mins

The Burj Khalifa

20 mins

Dubai Mall

25 mins

Burj Al Arab

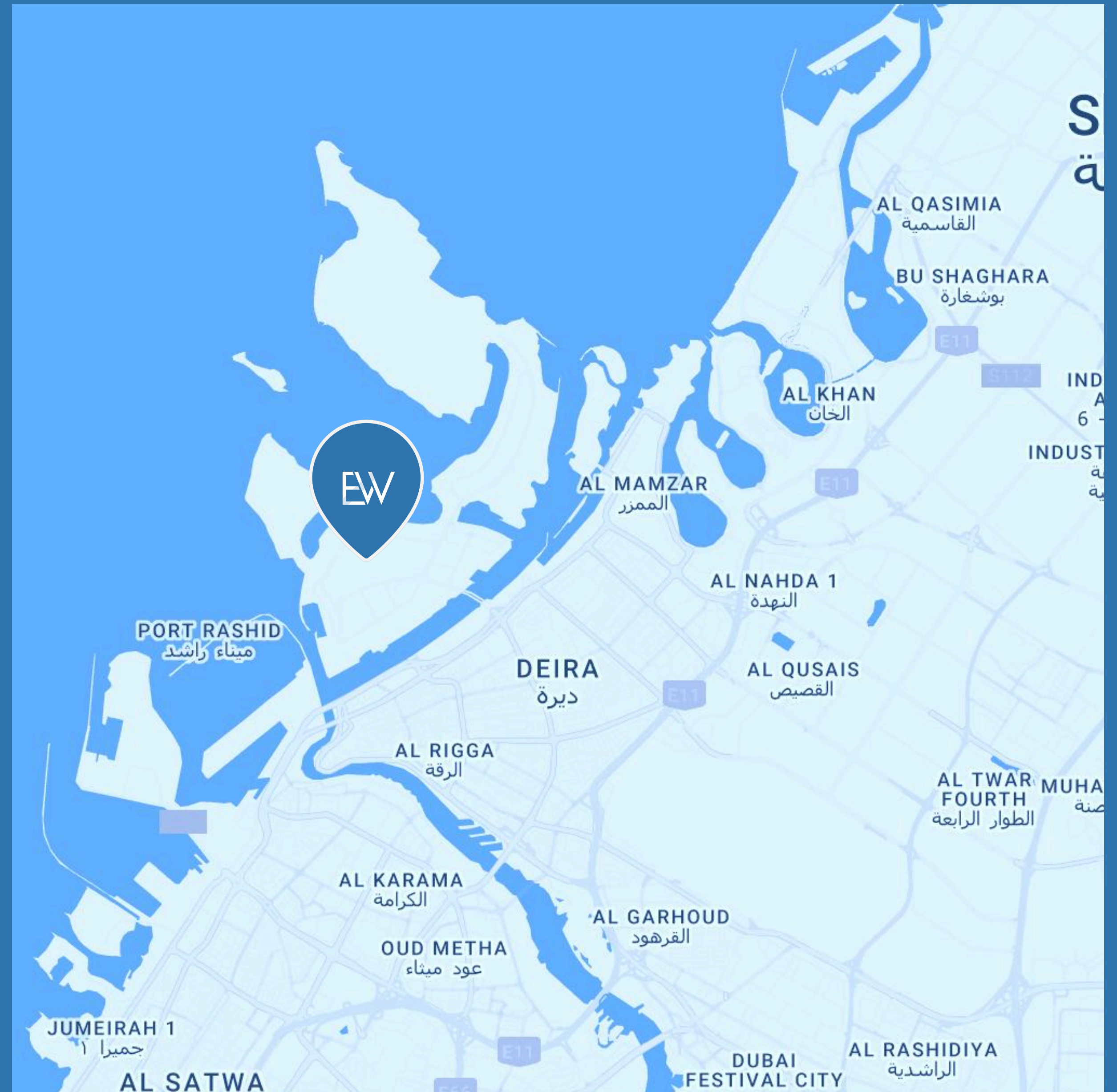



Why Dubai?

Tax-Free Environment

No income, capital gains, or inheritance tax.

Lucrative Rental Yields

One of the highest ROIs in the world, typically between 5-9%.

Residency Visa

Investors can obtain a 2-year visa or a 10-year Golden Visa, including sponsorship benefits.

High Quality of Life

Ranked #1 in the MENA region and #6 globally in the World's Best Cities Index 2024 by Resonance Consultancy.

100% Safety

Dubai is ranked the 4th safest city in the world in 2024, according to Numbeo.

About project

Set on the serene Dubai Islands, **Edgewater Residences** reaches its pinnacle with Phase 3 — the final and most luxurious chapter of this prestigious development. Comprising three elegant 12-storey towers, this exclusive collection is designed for those who seek refined coastal living amidst lush greenery and pristine shorelines.



Located on the prestigious Shore Island, **Edgewater Residence** will offer luxury living with premium residences, resorts, marinas, golf courses, and wellness retreats.

Residents will enjoy fine dining, boutique shopping, and the upcoming Dubai Islands Mall, which is set to surpass Dubai Mall in size by 20%.



Interior

Living Room



Bedroom





Bathroom



PREMIUM QUALITY FINISHES

Entrance Hall



Walls
Porcelain Slabs
Size: 320x150 cm Surface
Look, Polished

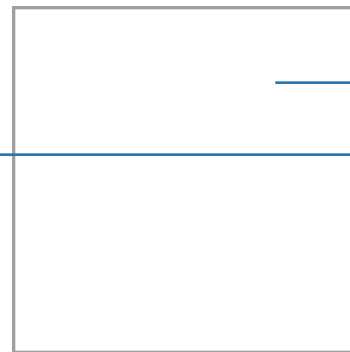

Ceiling
Gypsum Board, Paint
White Color

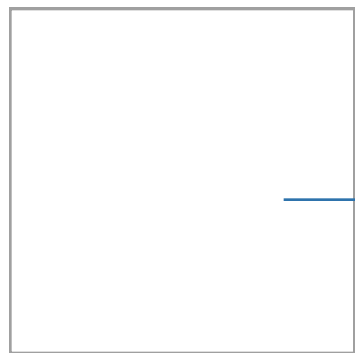

Walls
Wooden Cladding,
Painted MDF Wood

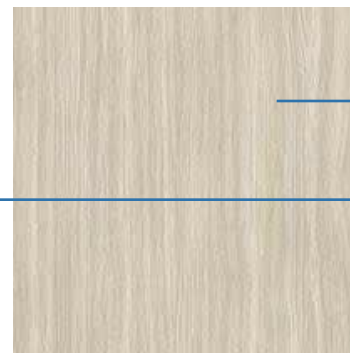

Walls
Wooden MDF Cladding,
Natural Veneer

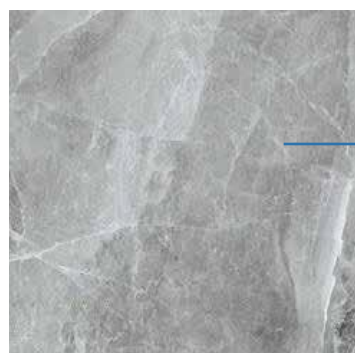

Floor
Marble, Tiles
Size: 120x120 cm Surface
Look, Polished



Walls
Jotun Paint, Light Grey





PREMIUM QUALITY FINISHES

Lift Lobby



Ceiling
Gypsum Board, Paint
White Color



Wall Cladding
Black Glass Mirror

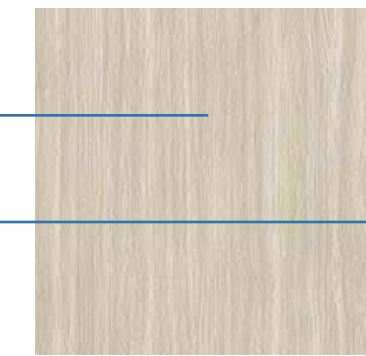

Wall Cladding
Wooden MDF Cladding,
Natural Veneer



Lift Doors
Polished Dark Stainless
Chrome

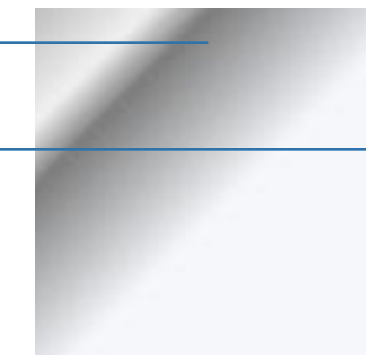

Wall Cladding
Polished Dark Stainless
Chrome

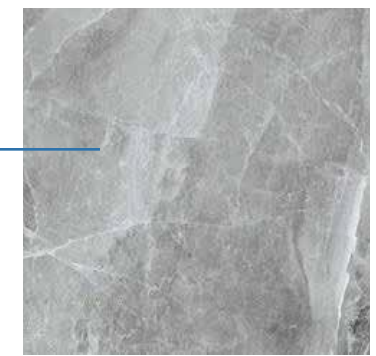

Floor
Marble, Tiles
Size:120x120 cm Surface
Look, Polished

PREMIUM QUALITY FINISHES

Typical corridor

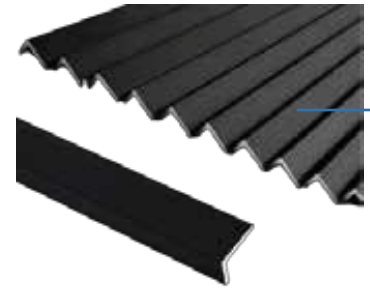

Horizontal Aluminum
L Channel
CRL SDCD516MBL
Matte Black 5/16"
Single Aluminum U
Channel

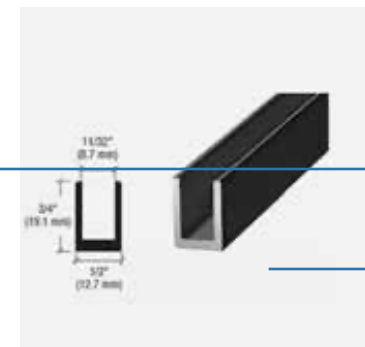

Vertical Aluminum
U - Channel
CRL SDCD516MBL
Matte Black 5/16" Single
Aluminum U-Channel

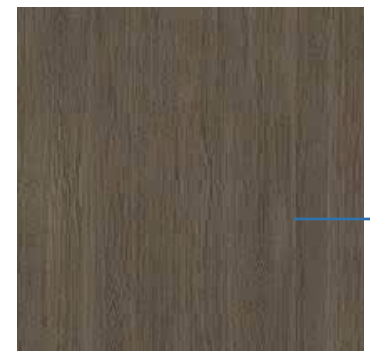

Corridor Doors
Door Size: 220x100 cm
Surface Look, Matt

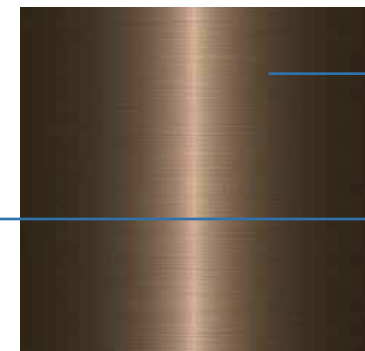

Bronze Metallic Platte
Door Size: 100x10cm
Surface Look, Matt

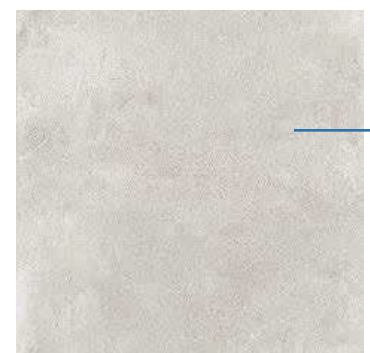

Wall
Jotun Paint Stucco
Effect

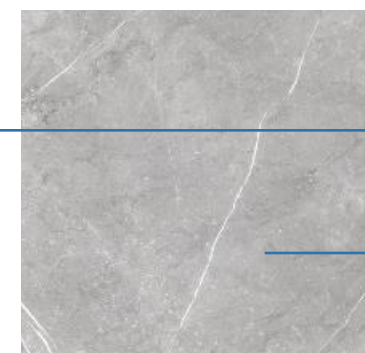

Floor & Skirting
Porcelain, Size: 120x60
cm Tiles Size:120x10 cm
Surface Look, Matt



PREMIUM QUALITY FINISHES

Throughout apartment

Living Room



Floor & Skirting
Porcelain, Size: 120x60 cm
Surface Look, Matt

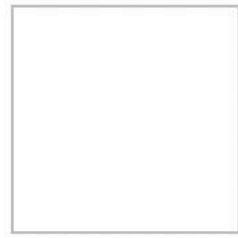

Ceiling
Paint White Color

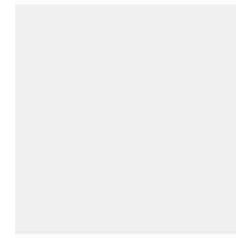

Walls
Off White Color

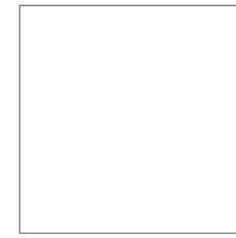

Doors
Laminate



Cabinet Doors
Laminate

Kitchen



Countertop
Engineered Stone



Wall
Between
Cabinet
Porcelain



Wardrobes
Doors
Laminate

Bedrooms

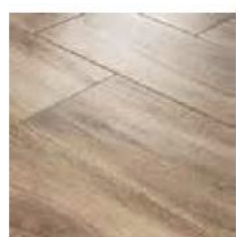

Floors &
Skirting
Porcelain



Ceiling
Paint White
Color

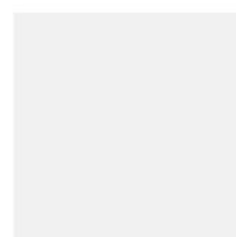

Walls
Off White
Color

Bathroom

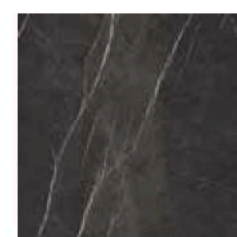

Tile
Armani
Grey

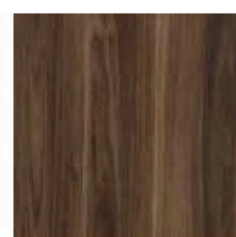

Vanity
Countertop:
Vanity Doors:
Laminated HPL



Walls &
Floor
Porcelain Tiles

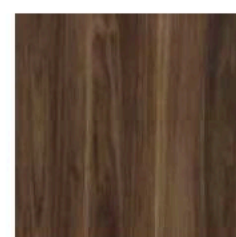

Wardrobe
Laminated MDF
Wood

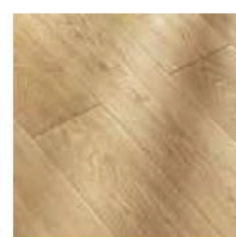

Walls
Porcelain Tiles



Ceiling
Paint White
Color



Lighting

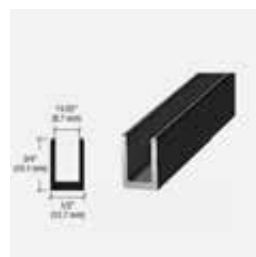

Horizontal Aluminum U-Channel
Between walls and skirting termination
CRL SDCD516MBL Matte Black 5/16" Single Aluminum
UChannel

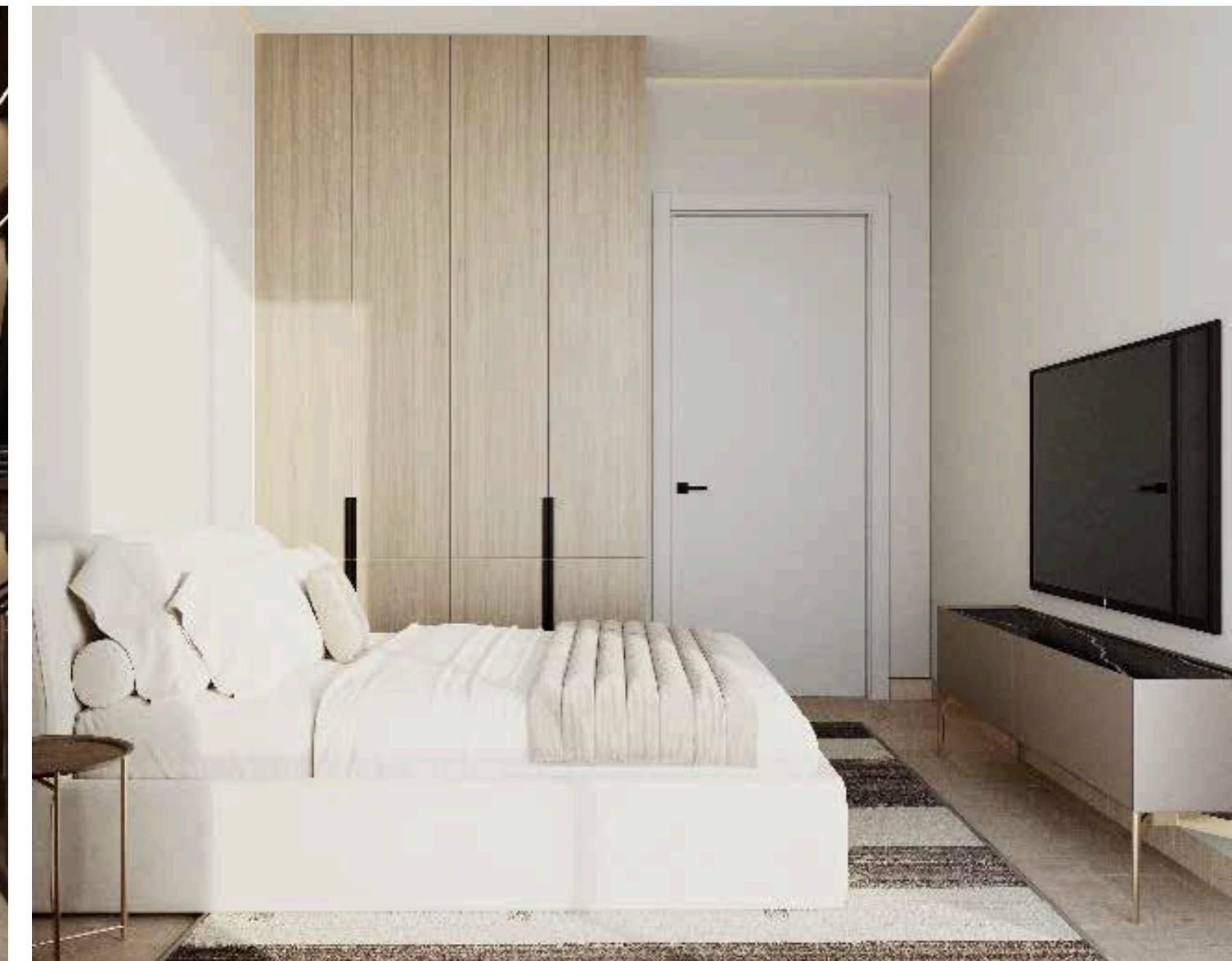

Exterior







EW

EDGEWATER
RESIDENCES

P





Outdoor amenities



Kids pool



Seating promenade



Overflow pool



Table tennis



Outdoor gym



Yoga space



Playground



Quiet zone



Jogging track



Padel court



Indoor amenities



Kids playing room



Gym



Common room



Building

3
towers

12 residential
floors per each

2 podium
floors

Premium collection of semi fitted apartments with high-quality **BOSCH** kitchen appliances. Top-floor apartments will offer stunning sea views and golf courses from the 5th floor.



Unit Types

1 BR Apartment

from 646 to 1,477 sq.ft — Starting Price **2.1 M AED**

2 BR Apartment

from 1,081 to 2,162 sq.ft — Starting Price **2.9 M AED**

3 BR Apartment

from 1,533 to 3,576 sq.ft — Starting Price **3.9 M AED**

HANDOVER:
Q2 2027

Payment plan

35/65

5%
Booking

10%
1st Installment

5%
2nd
Installment

10%
3 Installment

5%
4th
Installment

65%
Handover